

Gölümseyen Yüzeyler
vibromak

YÜZEY İŞLEM TEKNOLOJİLERİ SANAYİ VE TİCARET LİMİTED ŞİRKETİ
SURFACE TREATMENT TECHNOLOGIES INDUSTRY AND TRADE LIMITED COMPANY

VİBRASYON YÜZEY İŞLEM MAKİNELERİ
VIBRATORY SURFACE TREATMENT MACHINES

AŞINDIRICI VE PARLATICI TAŞLAR
GRINDING AND POLISHING CHIPS

KURUTMA VE PARLATMA
GRANÜLLER
DRYING AND POLISHING
GRAINS

YÜZEY İŞLEM KİMYASALLARI
SURFACE TREATMENT
COMPOUNDS



HAKKIMIZDA

VİBROMAK YÜZEY İŞLEM TEKNOLOJİLERİ SANAYİ ve TİCARET LTD. ŞTİ. olarak 1994 yılından itibaren sektör bilgi birikimimizle Ankara Merkez ve İstanbul/İkitelli İSDOK Sanayi Sitesi'ndeki şubemizle yüzey işlem sektöründe hizmet vermekteyiz.

Yerli imal ettiğimiz vibrasyon makinaları ile makine ortamında kullanılan taş, granül ve yüzey işlem kimyasallarını kaliteli ve ekonomik fiyatla sizlere sunuyoruz.

İç pazarda hızla artan satış potansiyelimize paralel olarak ihracat yaptığımız ülke sayısı da her geçen gün artmaktadır.

7/24 satış sonrası hizmet desteğine de önem vererek TS-EN -ISO 9001-2008 standardına ve bağlı olduğu yönetmeliklere uygun olarak, çağımızın gerektirdiği teknolojiye sahip, donanımlı ve akılcı çalışma metotları ile kaliteli, eğitilmiş, kendi alanında uzmanlaşmış, sürekli gelişime açık ve kalite sistemini benimsemiş personel ile faaliyet gösteren kuruluşumuz sürekli müşteri memnuniyetini sağlamayı ilke edinmiştir.

ABOUT US

We as **VIBROMAK SURFACE TREATMENT TECHNOLOGIES INDUSTRY AND TRADE COMPANY LIMITED** have been provided service in surface finishing sector in our branch in Ankara Centrum and İstanbul/İkitelli İSDÖK Industrial Area with our sectoral knowledge since 1994.

We present you chips, granules, and surface finishing compounds used in machinery with the vibratory machines we have manufactured domestically, with quality and economical prices.

The number of countries we export has been increasing each passing day, in parallel with our rapidly increasing sales potential in domestic market.

Our corporation which is active with personnel who have the technology required by our age and are equipped and qualified with the rational operation methods and educated, specialized, continuously opened for improvement and have adopted the quality system, in compliance with TS-EN-ISO 9001-2008 standard and affiliated regulations paying attention to the after sales support twenty-four-seven adopts as a principle providing continuous customer satisfaction.



2 yıl garanti

düşük maliyet

zaman kazandırır

doğru çözümler

YAPILAN İŞLER TRANSACTIONS

Çapak Alma / Deburring

Parlatma / Polishing

Köşe Kırma / Radiusing

Yağ Alma / Oil Cleaning

Pas Alma / Rust Cleaning

Oksit Açma / Antic Oxide

Tufal Alma / Descaling

Yıkama / Cleaning

Polisaj

İŞLENEN MALZEMELER MATERIALS APPLICATIONS

Alüminyum / Aluminium

Demir-Çelik / Iron-Steel

Bakır / Copper

Pirinç / Brass

Zamak / Zamak

Toz Metal / Powder Metal

Altın-Gümüş / Gold-Silver

Kurşun / Lead

Titanyum / Titanium

ABS & Polyester

Kauçuk / Rubber

Akrilik / Acrylic

Bakalit / Bacalite

Paslanmaz Çelik / Stainless Steel

Hassas Döküm / Precision Casting

KULLANIM ALANLARI APPLICATION AREAS

Mobilya aksesuar parçaları
Furniture accessory parts

Sac pres parçaları
Sheet metal press parts

Enjeksiyon, savurma, kum, kokil, döküm parçaları
Injection molding, centrifugal, sand, gravity die casting parts

Her türlü talaşlı imalat parçaları
All kinds of parts machining

Armatür ve vana parçaları
Fitting and valve parts

Çatal, kaşık, bıçak
Fork, spoon, knife

Tıbbi ve cerrahi aletler
Medical and surgical instruments

Akrilik diş ve diğer parçalar
Acrylic teeth and other dental parts

Otomotiv sanayi parçaları
Automotive parts industry

Havacılık ve uçak endüstri ürünleri
Aviation and aircraft industry

Kuyumculuk ve mücevher parçaları
Jewelry parts

Bijuteri ve aksesuar parçaları
Costume jewelry and accessory parts

Mermer ve doğal taş eskitme
Tumbled marble and natural stone

2 Years
Guarantee

low
cost

time
saving

accurate
solutions

VKO SERİSİ
VKO SERIES

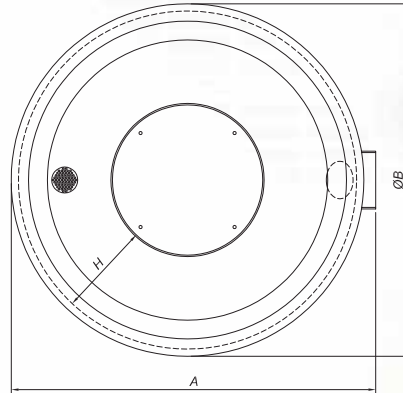
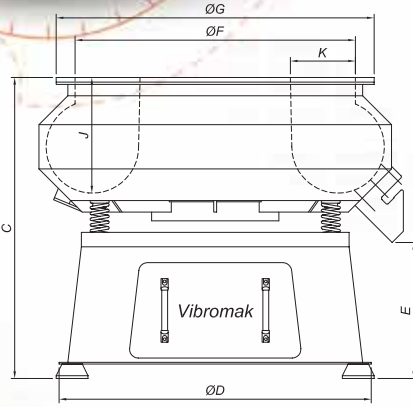

teknik özellikler technical specifications

TİP TYPE	Brüt Hacim Gross Volume Lt	PU Kalınlığı PU Thickness mm	Motor Gücü Engine Power kw	Gerilim Voltage 3 Faz - Phase	Çalışma Devri Operating Speed rpm	Ağırlık Weight Kg
VKO 75	75	15-20	0.75	380/50	1500	155
VKO 150	150	15-25	1.1	380/50	1500	315
VKO 250	275	15-25	1.5	380/50	1500	550
VKO 350	350	15-25	2.2	380/50	1500	610
VKO 500	500	15-25	3.0	380/50	1500	680
VKO 650	690	20-30	5.5	380/50	1500	1300
VKO 1000	1075	20-30	7,5	380/50	1500	1800
VKO 1300	1335	20-30	11,0	380/50	1500	2010

TİP - TYPE	A	B	C	D	E	F	G	H	J	K
VKO 75	765	740	830	680	470	600	700	230	270	200
VKO 150	1035	1000	900	770	470	800	930	240	340	170
VKO 250	1260	1220	1040	1120	470	970	1100	320	400	230
VKO 350	1360	1320	1050	1180	470	1090	1250	370	410	285
VKO 500	1470	1440	1135	1280	500	1130	1270	420	470	310
VKO 650	1650	1620	1180	1400	500	1300	1430	470	530	330
VKO 1000	2000	2000	1440	1700	620	1590	1740	530	600	400
VKO 1300	2140	2140	1500	1750	620	1700	1760	585	620	460

Eleksiz Vibrasyon Yüzey İşlem Makineleri
Vibratory Surface Finishing Machines without Separator

VKU SERİSİ
VKU SERIES

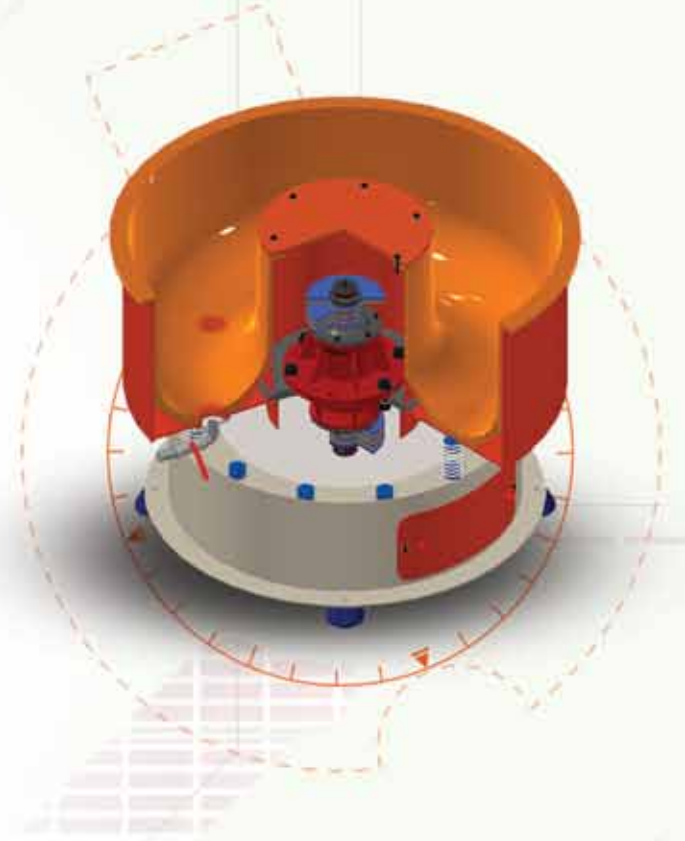
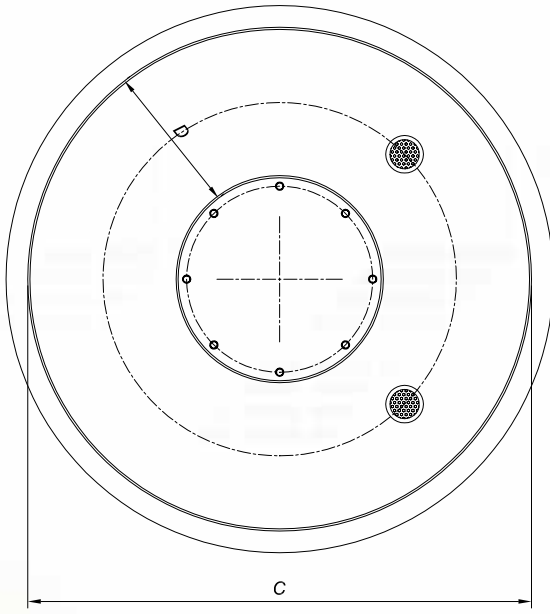
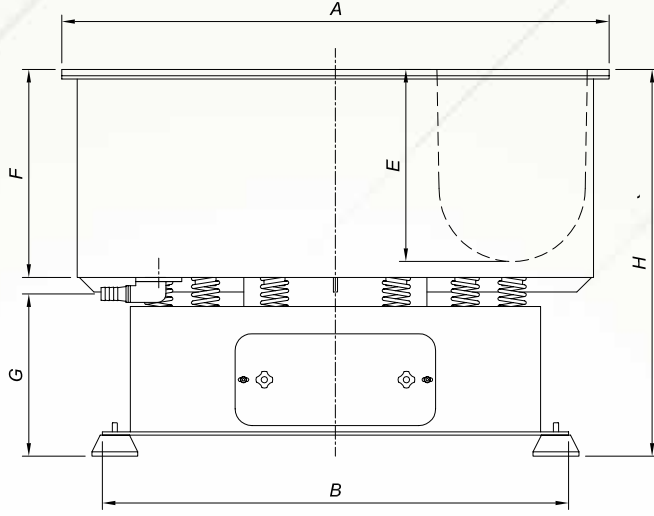

teknik özellikler technical specifications

TİP TYPE	Brüt Hacim Gross Volume Lt	PU Kalınlığı PU Thickness mm	Motor Gücü Engine Power kw	Gerilim Voltage 3 Faz - Phase	Çalışma Devri Operating Speed rpm	Ağırlık Weight Kg
VKU25	25	15-20	0.37	380 / 50	1500	105
VKU50	50	15-20	0.55	380 / 50	1500	138
VKU100	100	15-20	0.75	380 / 50	1500	218
VKU200	200	15-20	1.1	380 / 50	1500	345
VKU400	400	15-20	2.2	380 / 50	1500	605
VKU600	600	15-20	3	380 / 50	1500	810
VKU800	800	15-20	5.5	380 / 50	1500	1030
VKU1000	1000	15-20	5.5	380 / 50	1500	1215
VKU1200	1200	15-20	7.5	380 / 50	1500	1375

TİP - TYPE	A	B	C	D	E	F	G	H
VKU25	625	550	530	180	150	175	325	550
VKU50	700	590	610	210	215	250	325	615
VKU100	820	660	730	250	300	335	360	735
VKU200	1060	860	955	280	375	410	360	810
VKU400	1310	1120	1205	360	460	500	390	925
VKU600	1530	1290	1410	410	520	560	405	1000
VKU800	1680	1390	1560	460	570	610	455	1100
VKU1000	1760	1420	1620	490	630	670	455	1175
VKU1200	1890	1500	1760	550	650	690	455	1200

Tüm ölçüler milimetredir./All dimensions are millimeters.

VKUE SERİSİ
VKUE SERIES

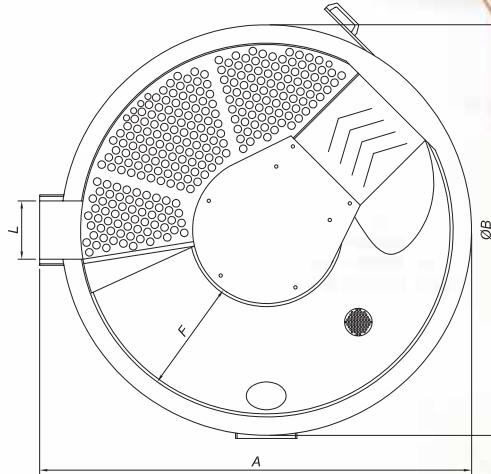
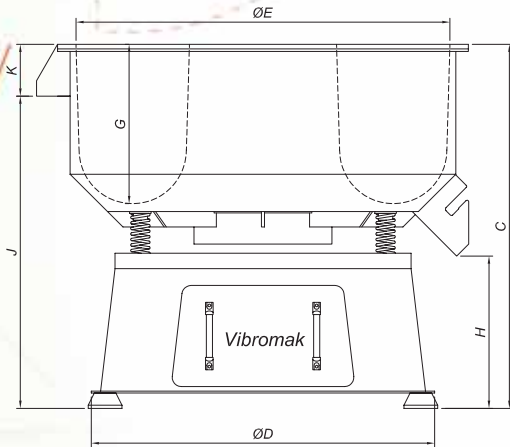

teknik özellikler technical specifications

TİP TYPE	Brüt Hacim Gross Volume Lt	Elek Yüzey Alanı Separator Surface Area m ²	PU Kalınlığı PU Thickness mm	Motor Gücü Engine Power kw	Gerilim Voltage 3 Faz - Phase	Çalışma Devri Operating Speed rpm	Ağırlık Weight Kg
VKUE 75	80	0,14	15-25	0,75	380/50	1500	185
VKUE 150	175	0,21	15-25	1.1	380/50	1500	290
VKUE 300	330	0,32	15-25	1.5	380/50	1500	430
VKUE 400	460	0,39	15-25	2.2	380/50	1500	560
VKUE 500	545	0,48	15-25	3.0	380/50	1500	720
VKUE 750	865	0,73	20-30	5.5	380/50	1500	1350
VKUE 1200	1210	0,98	20-30	7,5	380/50	1500	1840
VKUE 1600	1610	1,08	20-30	11,0	380/50	1500	2040

TİP - TYPE	A	B	C	D	E	F	G	H	J	K	L
VKUE 75	825	775	700	660	690	230	270	405	620	80	180
VKUE 150	1070	1010	960	940	910	280	400	470	810	150	240
VKUE 300	1310	1240	1100	1060	1120	320	460	490	930	170	250
VKUE 400	1410	1340	1190	1120	1220	370	520	490	1020	170	300
VKUE 500	1510	1430	1190	1140	1320	400	540	470	1020	170	340
VKUE 750	1760	1700	1330	1400	1560	450	630	530	1150	180	400
VKUE 1200	1970	1910	1480	1660	1760	550	650	630	1300	180	500
VKUE 1600	2240	2170	1560	1750	2010	610	675	630	1380	180	540

Tüm ölçüler milimetredir./All dimensions are millimeters.

Yatay Vibrasyon Yüzey İşlem Makineleri Linear Vibratory Surface Finishing Machines

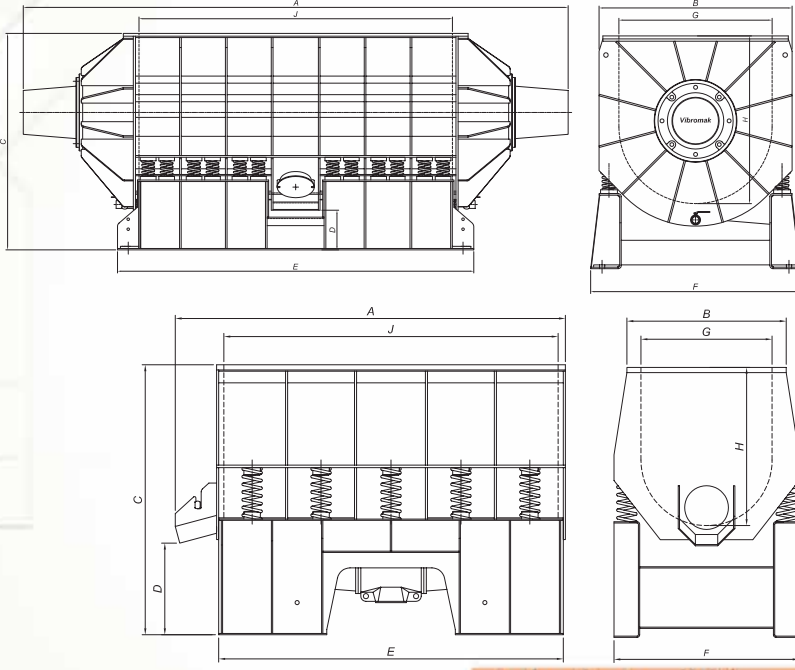

VKT SERİSİ
VKT SERIES



teknik özellikler technical specifications

TİP TYPE	Brüt Hacim Gross Volume Lt	PU Kalınlığı PU Thickness mm	Motor Gücü Engine Power kw	Gerilim Voltage 3 Faz - Phase	Çalışma Devri Operating Speed rpm	Ağırlık Weight Kg
VKT 15	15	15-20	0,37	380/50	1500	65
VKT 50	50	15-20	0,55	380/50	1500	150
VKT 100	100	15-20	1,1	380/50	1500	300
VKT 200	200	15-20	1,5	380/50	1500	510
VKT 300	300	15-20	2,2	380/50	1500	710
VKT 500	500	20-25	5,5	380/50	1500	1060
VKT 800	800	20-25	2*3	380/50	1500	1400
VKT 1000	1000	20-25	2*5,5	380/50	1500	2120
VKT 1600	1600	25-30	2*7,5	380/50	1500	2690
VKT 2200	2200	25-30	2*7,5	380/50	1500	3250

TİP - TYPE	A	B	C	D	E	F	G	H	J
VKT 15	690	290	570	300	540	370	180	200	500
VKT 50	910	370	700	300	760	450	260	300	720
VKT 100	1090	440	780	300	940	520	320	380	900
VKT 200	1300	520	895	300	1140	600	400	500	1100
VKT 300	1550	580	970	320	1400	680	440	550	1340
VKT 500	1720	740	1050	320	1560	820	600	620	1500
VKT 800	3030	860	1250	300	1900	940	700	800	1600
VKT 1000	3370	970	1300	300	2030	1080	750	850	1800
VKT 1600	3700	1140	1400	300	2300	1250	880	1000	2000
VKT 2200	3820	1260	1520	300	2500	1370	1000	1100	2200

Tüm ölçüler milimetredir./All dimensions are millimeters.

Yatay Vibrasyon Yüzey İşlem Makineleri Linear Vibratory Surface Finishing Machines

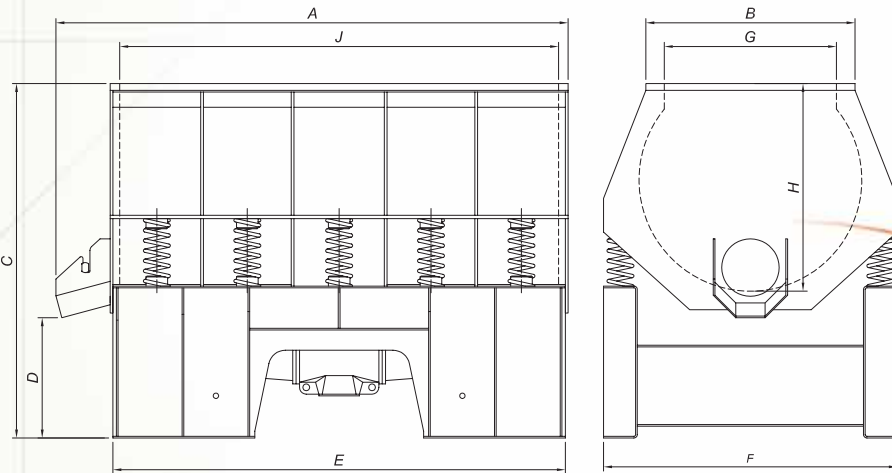

VKTO SERİSİ
VKTO SERIES



teknik özellikler technical specifications

TİP TYPE	Brüt Hacim Gross Volume Lt	PU Kalınlığı PU Thickness mm	Motor Gücü Engine Power kw	Gerilim Voltage 3 Faz - Phase	Çalışma Devri Operating Speed rpm	Ağırlık Weight Kg
VKTO 450	450	15-25	3	380/50	1500	560

TİP - TYPE	A	B	C	D	E	F	G	H	J
VKTO 450	1520	620	1050	360	1340	870	510	620	1300

Vibromak, makinaların renk ve teknik değerlerinin değişim hakkını saklı tutar / Vibromak reserves the right for changing the colors and technical values of the machines.

VKK SERİSİ
VKK SERIES



teknik özellikler technical specifications

TİP TYPE	Brüt Hacim Gross Volume Lt	Isıtıcı Gücü Heater Power W	Motor Gücü Engine Power kw	Gerilim Voltage 3 Faz - Phase	Çalışma Devri Operating Speed rpm	Ağırlık Weight Kg
VKK 100	100	2000	1.1	380/50	1500	300
VKK 200	200	3000	1.5	380/50	1500	410
VKK 400	400	3000	3.0	380/50	1500	630
VKK 600	600	4000	5.5	380/50	1500	860

TİP - TYPE	A	B	C	D	E	F	G	H	J	K	L	M	N
VKK 100	1030	880	930	780	430	800	300	950	250	830	100	180	220
VKK 200	1260	1090	980	880	440	1030	305	1150	300	880	100	180	250
VKK 400	1340	1180	1170	980	630	1100	350	1240	350	1020	150	180	300
VKK 600	1620	1480	1250	1280	650	1400	450	1540	440	1050	200	180	360

Tüm ölçüler milimetredir./All dimensions are millimeters.

Santrifüj Yüzey İşlem Makineleri
Centrifugal Surface Finishing Machines

VKS SERİSİ
VKS SERIES

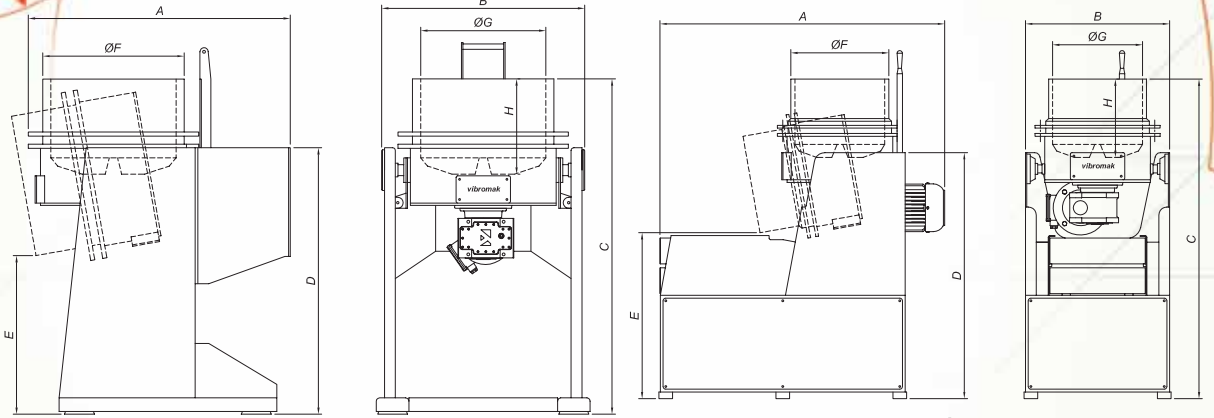
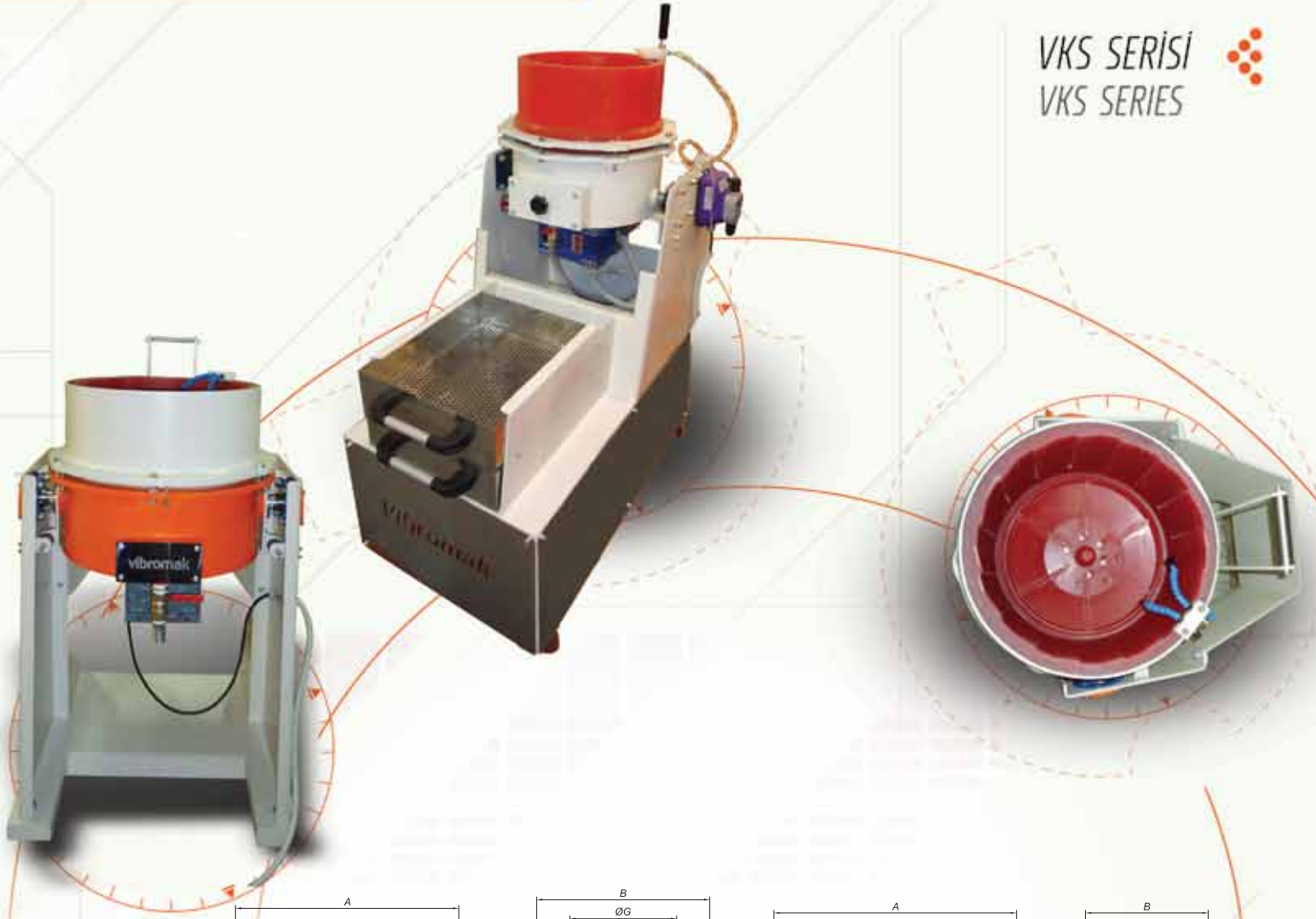

VKS50 - VKS100 - VKS230

VKS20

teknik özellikler technical specifications

TİP TYPE	Brüt hacim Gross Volume Lt	Motor Gücü Engine Power kw	Gerilim Voltage 3 Faz - Phase	Çalışma Devri Operating Speed rpm	Ağırlık Weight Kg
VKS 20	20	0,75	380/50	0-240	160
VKS 50	50	1,5	380/50	0-210	300
VKS 100	100	3,0	380/50	0-190	520
VKS 230	230	7,5	380/50	0-190	1100

TİP - TYPE	A	B	C	D	E	F	G	H
VKS 20	1045	530	1175	900	610	360	330	290
VKS 50	965	750	1235	980	585	520	460	350
VKS 100	1035	990	1385	1085	580	600	560	420
VKS 230	1340	1320	1600	1370	700	860	800	480

VKDT SERİSİ
VKDT SERIES

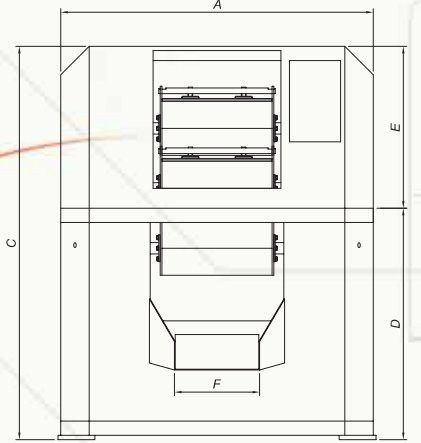
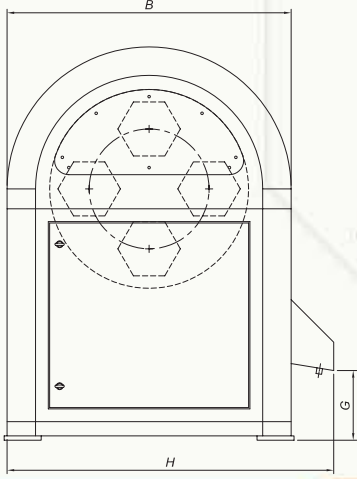

teknik özellikler technical specifications

TİP TYPE	Brüt hacim Gross Volume	Motor Gücü Engine Power	Gerilim Voltage	Çalışma Devri Operating Speed	Ağırlık Weight
	Lt	kw	3 Faz - Phase	rpm	Kg
VKDT 18	4,5X4	1,5	380/50	0-210	240
VKDT 30	7,5X4	2,75	380/50	0-210	410

TİP - TYPE	A	B	C	D	E	F	G	H
VKDT 18	770	900	1350	735	615	-	-	1000
VKDT 30	1100	1000	1420	850	570	300	280	1150

Tüm ölçüler milimetredir./All dimensions are millimeters.

VKSK SERİSİ
VKSK SERIES

Santrifüj Kurutma ve Yağ Alma makineleri
Centrifugal Dryer and Degreasing Machines

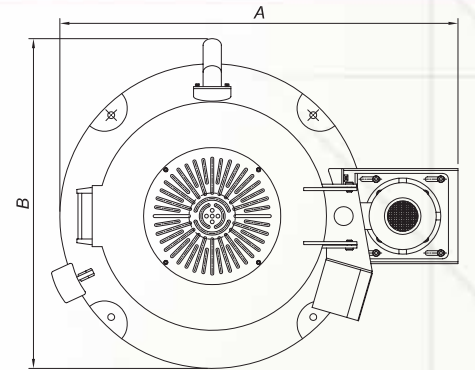
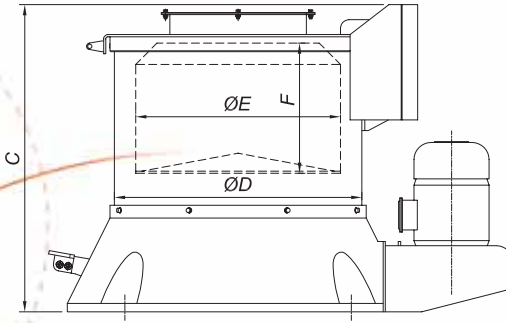

teknik özellikler technical specifications

TİP TYPE	Brüt Hacim Gross Volume	Motor Gücü Engine Power	Gerilim Voltage	Çalışma Devri Operating Speed	Isıtıcı Gücü Heater Power	Ağırlık Weight
	Lt	kw	3 Faz	rpm	W	Kg
VKSK 50	48	1,5	380/50	620	2000	240
VKKA 50	48	1,5	380/50	620	—	235

TİP - TYPE	A	B	C	D	E	F
VKSK 50	1050	870	720	580	480	305
VKKA 50	1050	870	720	580	480	305

Vibrasyon Yer Eleklri Vibratory Separators

VKYE SERİSİ
VKYE SERIES



teknik özellikler technical specifications

TİP TYPE	Kapasite Capacity Lt	Dış Ölçü Outside Dimension mm	İç Ölçü Inside Dimension mm	Ağırlık Weight Kg
VKYE 35	35	440x650x1240	350x730	100
VKYE 50	50	700x670x1850	500x850	150

Tüm ölçüler milimetredir./All dimensions are millimeters.

Aluminyum Jant Parlatma Makineleri Aluminum Wheel Polishing Machines

VKJ SERİSİ
VKJ SERIES

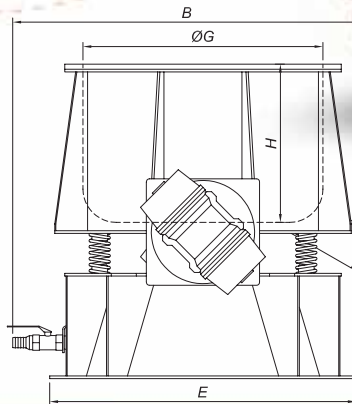
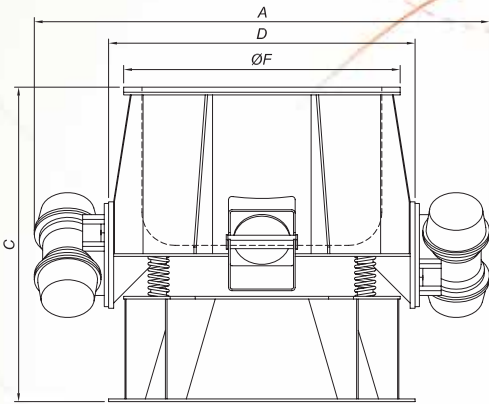





teknik özellikler technical specifications



TİP - TYPE	A	B	C	D	E	F	G	H
VKJ 140	1366	1050	950	920	920	830	720	475

TİP TYPE	Brüt Hacim Gross Volume Lt	Net Hacim Net Volume Lt	PU Kalınlığı PU Thickness mm	Motor Gücü Engine Power kw	Gerilim Voltage 3 Faz - Phase	Çalışma Devri Operating Speed rpm	Ağırlık Weight Kg
VKJ 140	188	140	15-25	2*0,75	380/50	1500	300

Vibromak, makinaların renk ve teknik değerlerinin değişim hakkını saklı tutar / Vibromak reserves the right for changing the colors and technical values of the machines.

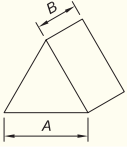
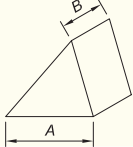
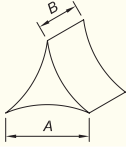
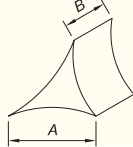
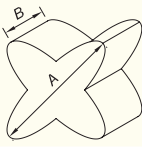
SERAMİK AŞINDIRICI TAŞLAR / CERAMIC GRINDING CHIPS

ÜÇGEN TRIANGLE		AÇILI ÜÇGEN OBLIQUE TRIANGLE		YILDIZ STAR		AÇILI YILDIZ OBLIQUE STAR		DÖRTGEN YILDIZ FOUR STAR	
ATG		AOG		ASG		AOSG		AFSG	
									
Teknik Çizimler - Technical Drawings									
									
Boyutlar - Dimensions									
4x4 6x6 10x10 13x13	16x16 20x20 25x15	25x25 30x30 40x40	10x10 13x13 16x12 16x16	20x20 25x25 30x30	10x10 19x19	10x10 13x13 25x25 30x30	22x12		

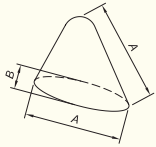
PİRAMİT PYRAMID		PARABOL PARABOLA		AÇILI SİLİNDİR OBLIQUE CYLINDER		AÇILI SİLİNDİR OBLIQUE CYLINDER		ELİPS ELLIPSE		MİSKET BALL	
TET		PA		AOCG		AOCG		AEG		ABG	
											
Teknik Çizimler - Technical Drawings											
											
Boyutlar - Dimensions											
30x30		30x17 50x28		30x15 30x30 40x40		8x20 15x40		20x10x20		6mm 8mm 10mm 20mm	

PLASTİK AŞINDIRICI TAŞLAR / PLASTIC GRINDING CHIPS

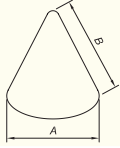
KONİK - CONE VYK-CONE PL	Teknik Çizimler Technical Drawings
	
Boyutlar - Dimensions	
12x12 19x19 25x25 30x30	35x35 40x40 50x50

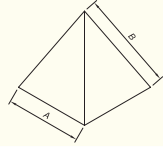
ÜÇGEN - TRIANGLE VYU-TET PHD	Teknik Çizimler Technical Drawings
	
Boyutlar - Dimensions	
25x25 35x35 45x45	

PORSELEN PARLATMA TAŞLARI / PORCELAIN POLISHING CHIPS



ÜÇGEN TRIANGLE	AÇILI ÜÇGEN OBLIQUE TRIANGLE	SİLİNDİR CYLINDER	AÇILI SİLİNDİR OBLIQUE CYLINDER	ELİPS ELLIPSE	MİSKET BALL	SÜPER MİSKET SUPER BALL	SÜPER AÇILI SİLİNDİR SUPER OBLIQUE CYLINDER		
YTP	YOTP	YCP	YOCP	YEP	YBP	YBPS	YOCPS		
Teknik Çizimler - Technical Drawings									
Boyutlar - Dimensions									
4x4 6x6 10x10	4x4 6x6 10x10	3x10 4x10 4x15 6x10	6x15 8x10 10x10 10x15	3x10 4x10 4x15 6x10 6x15	7x15 8x10 8x15 10x15	10x5x10 20x10x20	3mm 4mm 6mm 8mm 10mm	3mm 6mm	6x10

KURUTMA GRANÜLLERİ / DRYING GRAINS



MISIR GRANÜLÜ / CORN GRAINS

MG 4	MG 8	MG 16	MG 20	MG 30	MG 40	MG 60

PARLATMA GRANÜLLERİ / POLISHING GRAINS



FINDIK GRANÜLÜ / NUT GRAINS

FG 4	FG 8	FG 16	FG 20

CEVİZ GRANÜLÜ / WALNUT GRAINS

CG 4	CG 8	CG 16	CG 20



YÜZEY İŞLEM KİMYASALLARI

VİBRO-C ÇAPAK ALMA SIVISI

Bütün vibratör ve santrifüj makinelerde, seramik, plastik, üreik, porselen ve çelik bilya gibi medyalarla beraber, demir, çelik, paslanmaz, alüminyum, zamak, pirinç, bakır vb. malzemeden mamul parçalarda çapak alma, yağ alma ve oksit açma amacıyla kullanılır. Tavsiye edilen su ile karışım oranı %1 ile 5'dir. Koyu sarı renkli ve berrak bir sıvı olup PH=9,7 , Spesifik yoğunluğu =1,019 g/cm³'dür. Organik asit tuzları, non iyonik yüzey aktif maddeler ve korozyon inhibitörleri içermektedir. Suda çözülebilen çevre dostu bir üründür.

VİBRO-CS SÜPER ÇAPAK ALMA VE PARLATMA SIVISI

Bütün vibratör ve santrifüj makinelerde, seramik, plastik, üreik, porselen ve çelik bilya gibi medyalarla beraber, demir, çelik, paslanmaz, alüminyum, zamak, pirinç, bakır vb. malzemeden mamul parçalarda çapak alma, parlatma, yağ alma ve oksit açma amacıyla kullanılır. Tavsiye edilen su ile karışım oranı %1 ile 5'dir. Koyu sarı renkli ve berrak bir sıvı olup PH=8,50 - 9,50 spesifik yoğunluğu = 1000-1040 gr./cm³ 'tür. Organik asit tuzları, non iyonik ve korozyon inhibitörleri içermektedir. Suda çözülebilen çevre dostu bir üründür.

VİBRO-A OKSİT AÇMA VE PARLATMA SIVISI

Bütün vibratör ve santrifüj makinelerde, şeffaf plastik ve porselen parlatma taşları gibi medyalarla beraber, demir, çelik, paslanmaz, alüminyum, zamak, pirinç, bakır vb. malzemeden mamul parçalarda parlatma ve oksit açma amacıyla kullanılır. Tavsiye edilen su ile karışım oranı %1 ile 5'dir. Yeşil renkli ve berrak bir sıvı olup, PH=8,6 , Spesifik yoğunluğu =0.99 g/cm³ 'dür. Non iyonik yüzey aktif maddeler ve korozyon inhibitörleri içermektedir. Suda çözülebilen çevre dostu bir üründür. Köpüklenme özelliği yoktur, aynı zamanda köpük kesicidir.

VİBRO-P PARLATMA SIVISI

Bütün vibratör ve santrifüj makinelerde, şeffaf plastik ve porselen parlatma taşları gibi medyalarla beraber, demir, çelik, paslanmaz, alüminyum, zamak, pirinç bakır vb. malzemeden mamul parçalarda parlatma ve oksit açma amacıyla kullanılır. Tavsiye edilen su ile karışım oranı %1 ile 5'dir. Sarı renkli ve berrak bir sıvı olup, PH=8,93 , Spesifik yoğunluğu = 1010 g/cm³'dür. Non iyonik yüzey aktif maddeler ve korozyon inhibitörleri içermektedir. Suda çözülebilen çevre dostu bir üründür. Hafif köpüklenme özelliği vardır.

VİBRO-YP YAĞ VE PAS ALMA SIVISI

Bütün vibratör ve santrifüj makinelerde, seramik, plastik, üreik, porselen ve çelik bilya gibi medyalarla beraber, demir, çelik, paslanmaz, alüminyum, zamak, pirinç, bakır vb. malzemeden mamul parçalarda yağ alma, pas alma ve oksit açma amacıyla kullanılır. Tavsiye edilen su ile karışım oranı %1 ile 5'dir. Anyonik yüzey aktif ve asit içeren, renksiz ve berrak bir sıvı olup PH=1,68 Spesifik yoğunluğu = 1.306 g/cm³'dür. Suda çözülebilen çevre dostu bir üründür. Hafif köpüklenme özelliği vardır.

VİBRO-T YAĞ ALMA VE NÖTRALİZASYON TOZU

Bütün vibratör ve santrifüj makinelerde, seramik, plastik, üreik, porselen ve çelik bilya gibi medyalarla beraber, demir, çelik, paslanmaz, alüminyum, zamak, pirinç, bakır vb. malzemeden mamul parçalarda yağ alma ve nötrleme amacıyla kullanılır. Yüksek alkali, silikat ve yüzey aktifler içeren beyaz renkli bir tozdur. Suda çözülebilen çevre dostu bir üründür. Hafif köpüklenme özelliği vardır.

VİBRO-JEL PASTA

Alüminyum, zamak, prinç ve bakır malzemeden mamul parçalarda yağ alma ve çapak alma amacıyla kullanılır.

VİBRO-ZC ZAMAK PARLATMA SIVISI

Bütün vibratör ve santrifüj makinelerde, plastik, seramik, üreik, porselen ve çelik bilya gibi medyalarla beraber zamak malzemeden mamul parçalarda yağ alma, çapak alma ve parlatma amacıyla kullanılır. Tavsiye edilen su ile karışım oranı %1-5 dir. Hafif flue görünümde ve sarımsak renkte bir sıvı olup, PH=7.45, spesifik yoğunluğu=1.0160 g/cc'dir.

VİBRO-NC PARLATMA SIVISI

Bütün vibratör ve santrifüj makinelerde, plastik, seramik, üreik, porselen ve çelik bilya gibi medyalarla beraber alüminyum, prinç, bakır malzemeden mamul parçalarda yağ alma, çapak alma ve parlatma amacıyla kullanılır. Tavsiye edilen su ile karışım oranı %1-5 dir. Berrak görünümde ve sarımsak renkte bir sıvı olup, PH=2,51, spesifik yoğunluğu=1.029 g/cc'dir.

CLEANOX-ST PASLANMAZ TEMİZLEME SIVISI

Vibratör ve santrifüj makinelerde işlem yapmadan önce, paslanmaz, prinç ve bakır malzemeden mamul parçalarda statik ortamda daldırma yöntemi ile yağ alma, kaynak ve kaynaktan dolayı oluşan boraks kalıntılarının temizlenmesi amacıyla kullanılır. Tavsiye edilen su ile karışım oranı %1-20 dir. Berrak görünümde ve renksiz bir sıvı olup, PH=1.18, spesifik yoğunluğu=1.158 g/cc'dir.

VİBRO-AC ALÜMİNYUM PARLATMA SIVISI

Bütün vibratör ve santrifüj makinelerde, plastik, seramik, üreik, porselen ve çelik bilya gibi medyalarla beraber, naturel renkli eloksallama öncesi çok düşük silisli alüminyum malzemeden mamul parçalarda yağ alma, çapak alma ve parlatma amacıyla kullanılır. Tavsiye edilen su ile karışım oranı %1-5 dir. Hafif kıvamlı görünümde ve beyaz renkte bir sıvı olup, PH=2,25, spesifik yoğunluğu=1.078 g/cc'dir.



SURFACE FINISHING COMPOUNDS



VIBRO-C DEBURRING COMPOUND

It is intended for use of deburring, degreasing, and oxide removing for the items made of iron, steel, stainless, aluminum, zamak, brass, copper etc. along with the media such as ceramic, plastic, ureic, porcelain, and steel ball in all vibratory and centrifugal machines. The recommended mixing with water ratio is 1 - 5%. It is a dark yellow color and clear liquid and its pH is 9.7 and its specific density is 1.019 g/cm³. It contains organic acid salts, non-ionic surface active agents, and corrosion inhibitors. It is a water-soluble and environment-friendly product.

VIBRO-CS SUPER DEBURRING AND POLISHING COMPOUND

It is intended for use of deburring, degreasing, and oxide removing for the items made of iron, steel, stainless, aluminum, zamak, brass, copper etc. along with the media such as ceramic, plastic, ureic, porcelain, and steel ball in all vibratory and centrifugal machines. The recommended mixing with water ratio is 1 - 5%. It is a dark yellow color and clear liquid and its pH is 8.50 - 9.50 and its specific density is 1000 - 1040 g/cm³. It contains organic acid salts, non-ionic and corrosion inhibitors. It is a water-soluble and environment-friendly product.

VIBRO-A OXIDE REMOVING AND POLISHING COMPOUND

It is intended for use of polishing and oxide removing for the items made of iron, steel, stainless, aluminum, zamak, brass, copper etc. along with the media such as transparent plastic and porcelain polishing chips in all vibratory and centrifugal machines. The recommended mixing with water ratio is 1 - 5%. It is a green color and clear liquid and its pH is 8.6 and its specific density is 0.99 g/cm³. It contains non-ionic surface active agents and corrosion inhibitors. It is a water-soluble and environment-friendly product. It does not have foaming property and it is an anti-foaming agent.

VIBRO-P POLISHING COMPOUND

It is intended for use of polishing and oxide removing for the items made of iron, steel, stainless, aluminum, zamak, brass, copper etc. along with the media such as transparent plastic and porcelain polishing chips in all vibratory and centrifugal machines. The recommended mixing with water ratio is 1 - 5%. It is a yellow color and clear liquid and its pH is 8.93 and its specific density is 1010 g/cm³. It contains non-ionic surface active agents and corrosion inhibitors. It is a water-soluble and environment-friendly product. It has light foaming property.

VIBRO-YP DEGREASING AND RUST REMOVING COMPOUND

It is intended for use of degreasing, rest removing, and oxide removing for the items made of iron, steel, stainless, aluminum, zamak, brass, copper etc. along with the media such as ceramic, plastic, ureic, porcelain, and steel ball in all vibratory and centrifugal machines. The recommended mixing with water ratio is 1 - 5%. It is a colorless and clear liquid containing anionic surface active agent and acid and its pH is 1.68 and its specific density is 1.306 g/cm³. It is a water-soluble and environment-friendly product. It has light foaming property.

VIBRO-T DEGREASING AND NEUTRALIZATION POWDER

It is intended for use of degreasing and neutralizing for the items made of iron, steel, stainless, aluminum, zamak, brass, copper etc. along with the media such as ceramic, plastic, ureic, porcelain, and steel ball in all vibratory and centrifugal machines. It is a white color powder containing high alkali, silicate, and surface active agents. It is a water-soluble and environment-friendly product. It has light foaming property.

VIBRO-JEL PASTE

It is intended for use of degreasing and deburring for the items made of aluminum, zamak, brass and copper.

VIBRO-ZC ZAMAK POLISHING COMPOUND

It is intended for use of degreasing, deburring, and polishing for the items made of zamak along with the media such as plastic, ceramic, ureic, porcelain, and steel ball in all vibratory and centrifugal machines. The recommended mixing with water ratio is 1 - 5%. It is light blurred and yellowish color and its pH is 7.45 and its specific density is 1.0160 g/cc.

VIBRO-NC POLISHING COMPOUND

It is intended for use of degreasing, deburring, and polishing for the items made of aluminum, brass, copper etc. along with the media such as plastic, ceramic, ureic, porcelain, and steel ball in all vibratory and centrifugal machines. The recommended mixing with water ratio is 1 - 5%. It is a clear and yellowish color liquid and its pH is 2.51 and its specific density is 1.029 g/cc.

CLEANOX-ST STAINLESS CLEANING COMPOUND

It is intended for the use of degreasing with immersion method in a static environment and cleaning of weld and borax residues arising from welding for the items made of stainless, brass, and copper before performing an operation in vibratory and centrifugal machines. The recommended mixing with water ratio is 1-20%. It is clear and colorless liquid and its pH is 1.18 and its specific density is 1.158 g/cc.

VIBRO-AC ALUMINUM POLISHING COMPOUND

It is intended for use of degreasing, deburring, and polishing for the items made of aluminum with very low silica before natural and colored anodic coating along with the media such as plastic, ceramic, ureic, porcelain, and steel ball in all vibratory and centrifugal machines. The recommended mixing with water ratio is 1 - 5%. It is a light viscous and white color liquid and its pH is 2.25 and its specific density is 1.078 g/cc.

TİP / TYPE	VIBRO-C	VIBRO-CS	VIBRO-P	VIBRO-YP	VIBRO-NC
KULLANIM ALANI USING AREA	Çapak alma sıvısıdır. Yağ alma, çapak alma ve korozyon koruma özelliği vardır. It is the deburring compound. It has the properties of degreasing, deburring, and protection against corrosion.	Yağ alma ve korozyon koruma özelliği güçlü çapak alma sıvısı. It is the deburring compound with high properties of degreasing and protection against corrosion.	Genel amaçlı Parlatma sıvısı. It is the polishing compound for general purposes.	Asidik yağ ve pas alma sıvısı. It is the degreasing and rust removing acidic compound.	Yağ alma ve parlatma sıvısıdır. It is the degreasing and polishing compound.
PH DEĞERİ (% 1 - 20 C) PH VALUE	9,7	8,5	8,93	1,68	2,51
MALZEME MATERIAL					
DEMİR / ÇELİK IRON / STEEL	✓	✓ ✓	✓ ✓	✓ ✓	
BAKIR / PİRİNÇ COOPER / BRASS			✓	✓ ✓	
ALÜMİNYUM ALUMINIUM	✓	✓ ✓	✓		
DÜŞÜK SİLİSLİ ALÜMİNYUM ALUMINIUM WITHOUT SILICON					✓ ✓
ÇİNKO ZINC		✓	✓	✓	✓ ✓
PASLANMAZ ÇELİK STAINLESS STEEL		✓ ✓	✓ ✓	✓ ✓	✓
ZAMAK ZAMAK		✓	✓		
İŞLEM TREATMENT					
ÇAPAK ALMA DEBURRING	✓	✓ ✓			
KÖŞE KIRMA RADIUSING	✓	✓ ✓			
YAĞ ALMA OIL CLEANING		✓		✓ ✓	✓ ✓
PAS ALMA RUST CLEANING				✓ ✓	
TUFAL TEMİZLEME DESCALING				✓ ✓	
PARLATMA POLISHING		✓	✓ ✓	✓ ✓	✓ ✓
KOROZYON KORUMA CORROSION PROTECT	✓	✓ ✓	✓ ✓		
ANTİK ANTIQUÉ			✓	✓	

VIBRO-T	VIBRO-ZC	CLEANOX-ST	VIBRO-AC	VIBRO-JEL	VIBRO-A
Alkali yağ alma ve nötralizasyon tozudur. It is the degreasing and neutralizing alkali powder.	Zamak yağ alma ve parlatma sıvısı. It is the degreasing and polishing compound for zamak.	Paslanmaz kaynak ve tufal temizleme sıvısı. It is the cleaning compound for stainless, weld and scale.	Eloksal öncesi alüminyum parlatma sıvısı. It is the polishing compound for aluminum before anodic coating.	Yağ alma ve çapak alma pastası It is the degreasing and deburring paste.	Oksit açma ve antik işlem parlatma sıvısı. It is the oxide removing and antique finishing compound.
12,84	7,45	1,18	2,25	9,73	8,6
✓ ✓					✓
				✓ ✓	✓ ✓
✓ ✓				✓ ✓	✓ ✓
✓ ✓			✓ ✓	✓ ✓	
✓					
		✓ ✓		✓ ✓	
	✓ ✓			✓ ✓	✓ ✓
				✓ ✓	
✓ ✓	✓ ✓	✓ ✓	✓ ✓	✓ ✓	
		✓ ✓			
	✓ ✓		✓ ✓	✓ ✓	✓
					✓
					✓ ✓





Ankara Merkez İstanbul

İvedik Organize Sanayi Bölgesi İkitelli Organize Sanayi Bölgesi
Özcanadolu Sanayi Sitesi 681. Sokak No:20 İsdök Sanayi Sitesi 2.B Blok No:2
06370 İvedik / ANKARA / TÜRKİYE İkitelli / İSTANBUL / TÜRKİYE
Tel: +90.312 394 44 90 Tel: +90.212 549 01 09
Faks: +90.312 394 44 92 Faks: +90.212 549 01 10

www.vibromak.com

Arçelik 1962
KURUMSAL İÇİŞİLERİ VE İHRAÇTAN SORUMLU
YATIRIM MENKUL DEĞERLER A.Ş.
Tic. Sic. No: 270900
Tel: (0312) 430 70 81



www.kosgeb.gov.tr

Basım Tarihi: 21.05.2013