

Deburring - Rounding - Grinding - Smoothing - Polishing

MR 56K - Centrifuge

the economic cycle system



MR 56K Centrifuge - Easy and clean water preparation

Compact cleaning and supply system with centrifuge and container (2 chambers for polluted and cleaning liquid.) For continuous separation of finest solid particles from liquids

Technical data

Continuous liquidity flow-rate	max. 60 l/min. Water
Drum volume	4,5 dm ³
Solid particles volume	3,0 dm ³
Drum speed	4050 min ⁻¹
Separating factor	1.800 g (1 g =acceleration of gravity)
Drive	Belt drive (0,75 kW) with a wear-free DC brake
Electrical connection	400 V / 50 Hz, 16 A - 2,4 kW
Solids removal	manual plastic insert, dry due to the flow of residual fluid.
Liquid return	Counter pressure approx. 0.5 bar at the case cover (peeling pipe)
Residual liquid drain	When shut down the centrifuge, the return liquid flows pressurless sideways of the centrifuge housing into the dirt tank.
Container	75 l dirt tank, 225 l Clean tank
Safety	Cover monitoring, standstill monitoring, motor protection
optional:	
Drop-in heat exchanger	Cooling capacity of 4500 W at an ambient temperature of 37°C and a medium temperature of 20°C

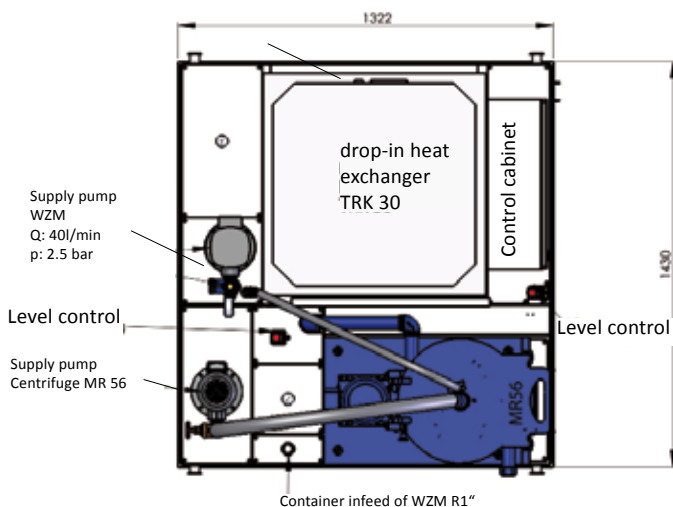

Top-view

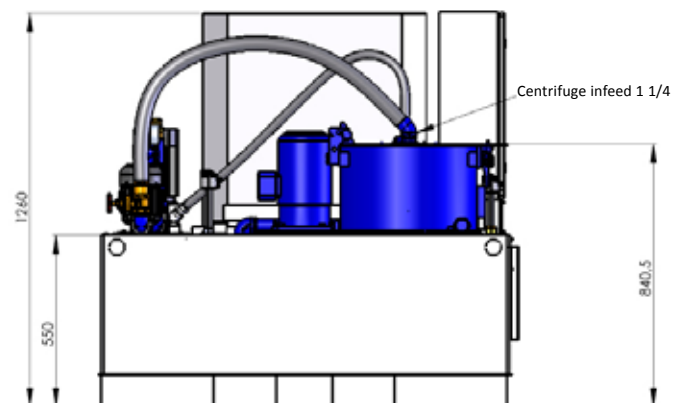

Side-view