

Elekli Vibrasyon Yüzey İşlem Makineleri

Vibratory Surface Finishing Machines with Separator



Ek Aksesuarlar

- Pnömatik Ses Kapağı
- Pnömatik Flap Kontrol
- Hız Kontrol
- Dozaj Pompası
- Manyetik Valf
- Elektrik Pano Standı
- Durulama Su Boru Sistemi

Additional Accesories:

- Pneumatic Sound Lid
- Pneumatic Flap Control
- Frequency Control
- Dossage Pump
- Magnetic Valve
- Control Panel Base
- Rinsing Pipe

VKUE serisi vibrasyon makineleri her türlü metal ve metal dışı malzemelerden mamül parçaların yüzey işlemlerinde kullanılan ve proses sonunda iş parçalarını taşlardan ayırma sistemine sahip elekli makinalardır.

VKUE series machines can be used for surface finishing of metal and nonmetal work pieces. These type of machines have large screen area and allow easy separation of work pieces from the media.

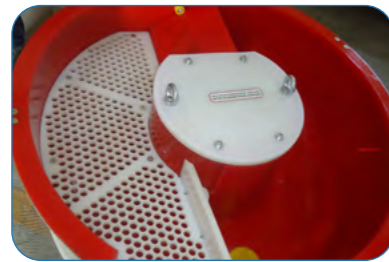

Changeable Screen
Değişebilir Elek



Ramp
Rampa



Pneumatic Flap Control (Optional)
Pnömatik Sistem Rampa Kontrol



Manual Flap Control
Manuel Rampa Kontrol



Electric Control Panel
Elektrik Panosu

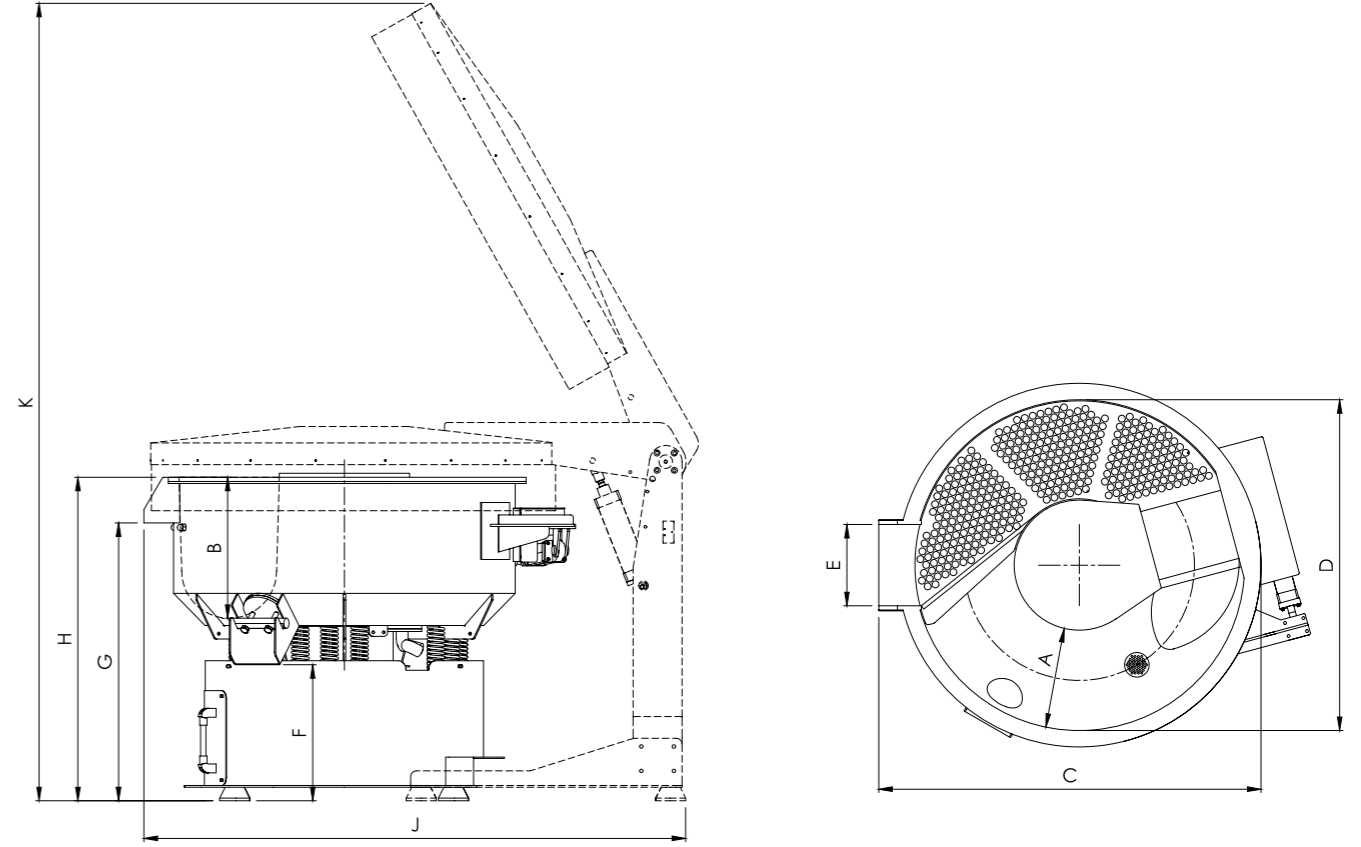

Teknik Ölçüler Technical Dimensions

TİP / TYPE		VKUE 100	VKUE 200	VKUE 350	VKUE 500	VKUE 800	VKUE 1200	VKUE 1600
Brüt Hacim Gross Volume	Lt	122	219	382	520	845	1210	1610
Elek Yüzey Alanı Screen Area	m ²	0,18	0,25	0,35	0,45	0,60	0,98	1,10
PU Kalınlığı PU Thickness	mm	15-25	15-25	15-25	15-25	15-25	15-25	15-25
Motor Gücü Engine Power	Kw	0,64	1,13	1,9	2,5	5,5	7	11
Gerilim Voltage	V/Hz	380/50	380/50	380/50	380/50	380/50	380/50	380/50
Çalışma Devri Operating Speed	rpm	1500	1500	1500	1500	1500	1500	1500
Ağırlık Weight	Kg	240	340	540	720	1050	1350	2050
A	mm	220	280	340	380	430	550	610
B	mm	350	400	470	540	585	655	675
C	mm	920	1080	1330	1500	1700	2000	2240
D	mm	800	960	1200	1360	1550	1760	2010
E	mm	200	250	300	340	400	500	540
F	mm	480	500	525	550	575	600	600
G	mm	800	820	920	990	1000	1240	1280
H	mm	930	980	1100	1200	1250	1440	1480
J	mm	1380	1540	1820	1980	2200	2620	3060
K	mm	2220	2300	2800	3050	3100	3700	3900

Tüm ölçüler milimetredir.
All dimensions are millimeters.

Vibromak makinaların renk ve teknik değerlerinin değişim hakkını saklı tutar.
Vibromak reserves the right for changing the colors and technical values of the machines.